

\$4.50

TROY-BILT®

Owner/Operator Manual

TROY-BILT® MINI-TILLER CULTIVATOR

- **Safety**
- **Assembly**
- **Operation**
- **Maintenance**
- **Parts List**

Model

12157

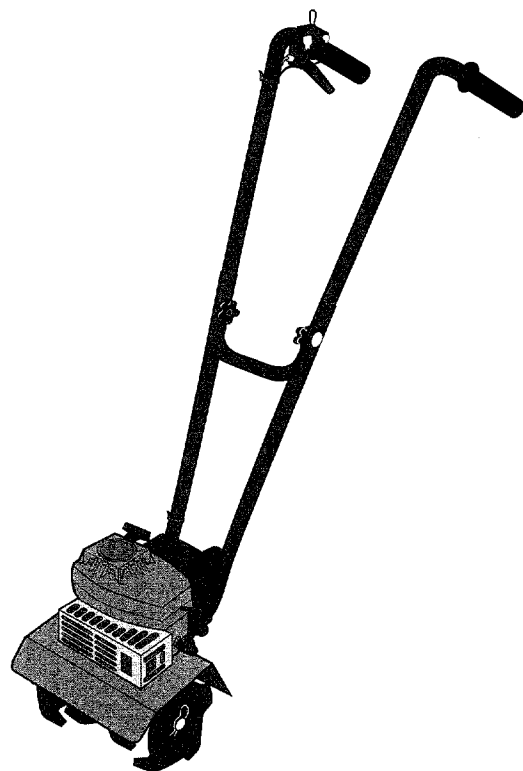

To help you as quickly as possible when you write or call for parts or service assistance, we'll need to know your tiller serial number. This number tells us when your machine was made and what features it has.

The arrow in the picture to the right points to the location of the serial number. For your convenience and ready reference, please enter the serial number below and fill in the date your tiller was delivered.

The Serial Number On My Tiller Is:

Date Tiller was Delivered:

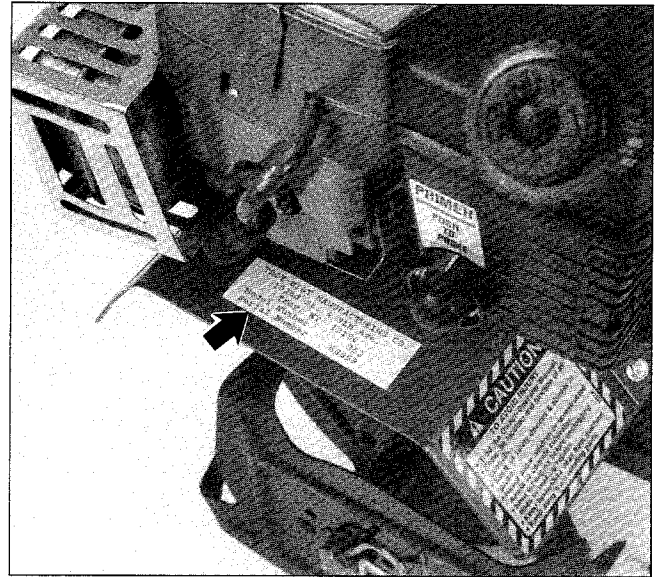

The Tiller Serial Number location.

! CAUTION

TO AVOID INJURY:

- READ THE OWNER / OPERATOR MANUAL.
- KNOW LOCATION AND FUNCTION OF ALL CONTROLS.
- KEEP ALL SAFETY DEVICES AND SHIELDS IN PLACE AND WORKING.
- NEVER ALLOW CHILDREN OR UNINSTRUCTED ADULTS TO OPERATE TILLER.
- SHUT OFF ENGINE AND DISCONNECT SPARK PLUG WIRE BEFORE UNCLOGGING TINES OR MAKING REPAIRS.
- KEEP BYSTANDERS AWAY FROM MACHINE.
- KEEP AWAY FROM ROTATING PARTS.
- USE EXTREME CAUTION WHEN REVERSING OR PULLING THE MACHINE TOWARDS YOU.

! WARNING:

The engine exhaust from this product contains chemicals known to the State of California to cause cancer, birth defects, or other reproductive harm.

! WARNING TO ALL CALIFORNIA AND OTHER POWER EQUIPMENT OPERATORS

Under California law, and under the laws of several other states, you are not permitted to operate an internal combustion engine using hydrocarbon fuels on any forest-covered, brush-covered, or grass-covered land, or on land covered with grain, hay, or other flammable agricultural crop, without an engine spark arrester in continuous effective working order.

The engine on your power equipment, like most outdoor power equipment, is an internal combustion engine that burns gasoline, a hydrocarbon fuel. Therefore, your power equipment must be equipped with a spark arrester muffler in continuous effective working order. The spark arrester must be attached to the engine exhaust system in such a manner that flames or heat from the system will not ignite flammable material. Failure of the owner / operator of the equipment to comply with this regulation is a misdemeanor under California law, and may also be a violation of other state and/or federal regulations, laws, ordinances, or codes. Contact your local fire marshal or forest service for specific information about what regulations apply in your area.

CONGRATULATIONS on your purchase of the TROY-BILT Mini-Tiller / Cultivator. It has been designed, engineered and manufactured to give you the best possible dependability and performance.

Should you experience any problems you cannot easily remedy, please contact your nearest authorized Dealer or the Factory.

Please read and retain this Manual. The instructions will help you assemble and maintain your machine properly. Always observe the "SAFETY RULES."

PRODUCT SPECIFICATIONS

HORSEPOWER:	1.6 HP
DISPLACEMENT:	2.0 CU. IN.
FUEL CAPACITY: (24:1 gasoline to 2-cycle oil mixture)	20 ozs.
SPARK PLUG (GAP 0.030-in.):	Champion CJ-6Y* or equivalent
IGNITION	Electronic
NET ENGINE WEIGHT	7.5 LBS.

* In Canada, replace spark plug with a resistor plug.

MODEL NUMBER: 12157

SERIAL
NUMBER: _____

DATE OF
PURCHASE: _____

THE MODEL AND SERIAL NUMBERS WILL BE FOUND ON A DECAL LOCATED ON THE HANDLEBARS OF YOUR MACHINE.

YOU SHOULD RECORD BOTH THE SERIAL NUMBER AND DATE OF PURCHASE AND KEEP IN A SAFE PLACE FOR FUTURE REFERENCE.

WARNING: This machine is equipped with an internal combustion engine and should not be used on or near any unimproved forest-covered, brush-covered or grass-covered land unless the engine's exhaust system is equipped with a spark arrester meeting applicable local or state laws (if any). If a spark arrester is used, it should be maintained in effective working order by the operator.

In the state of California the above is required by law (Section 4442 of the California Public Resources Code). Other states may have similar laws. Federal laws apply on federal lands. This engine is not equipped with a spark arrester for the muffler. A spark arrester for the muffler is available through your nearest authorized Engine Dealer.

This machine meets voluntary safety standard B71.8 – 1986, which is sponsored by the Outdoor Power Equipment Institute, Inc., and is published by the American National Standards Institute.



TROY-BILT FACTORY DIRECT 30-DAY TRIAL

TROY-BILT Mfg. wants you to be completely satisfied with your product. If you are not totally satisfied with the condition or performance of your TROY-BILT product, you may exchange your product or receive a refund of the purchase price of your merchandise. To receive your refund, you must contact us within 30 days after you receive your order, and follow the return instructions.

TABLE OF CONTENTS

Section 1: Safety	6
Section 2: Easy Assembly	9
Section 3: Operation	
The Gasoline / Two-Cycle Engine Oil Mixture.....	12
Starting and Stopping	12
Tilling And Cultivating.....	13
Tips and Techniques	14
Section 4: Maintenance	
Engine Lubrication	16
Transmission Lubrication	16
Engine Air Cleaner.....	17
Carburetor Adjustment	17
Cooling System.....	18
Spark Plug.....	18
Tine Removal and Installation	18
Narrow Cultivating.....	19
Storage	19
Parts Ordering Information	21
Replacement Parts	20
Maintenance Checklist	23
Specifications	23
Warranty	Back Cover

ENGINE SERVICE

If your tiller engine ever needs service or repair, or parts are required, please contact your nearest Tecumseh Service Dealer.

To find the nearest Service Dealer, look in the Yellow Pages of your telephone book under "Engines— Gasoline", or "Gasoline Engines."

If you have problems getting engine service or parts locally, let us know so we can provide you with the name of the nearest Service Dealer.

QUESTIONS OR PROBLEMS?

1. Check this Owner/Operator Manual:

The answer to your question or problem may be in this Manual. Refer to the Table of Contents on the previous page in this Manual to find the listing that concerns your problem. Turn to that page and read the information provided.

2. Contact your Local Dealer or the Factory:

If you can't find the answer to your question or problem in this Manual, please first contact your local Authorized Dealer. Factory assistance is available if needed. One of our helpful, friendly tiller experts will gladly help you. Be ready to provide your tiller model and the serial number of your tiller.

3. If you need a part:

Contact your local Authorized Dealer, or call or write to our Parts Department (see the Toll-Free telephone number below). Please have your tiller model and serial number at hand. Use the Parts Listing to find the part number, description, and quantity of the part you need. Remember that you can purchase many of the common hardware items at your local hardware store as well as ordering them from us.

For Customer Assistance, contact your nearest authorized dealer or:

Garden Way Incorporated • 1 Garden Way, Troy, New York U.S.A. 12180

Customer Service	1-800-437-8686
Technical Service	1-800-520-5520
Parts Service	1-800-648-6776
FAX:	(518) 391-7332

Outside the U.S.A. and Canada:

Customer Service	(518) 391-7007
Technical Service	(518) 391-7008
Parts Service	(518) 391-7006
FAX:	(518) 391-7332

Our Hours are (Eastern Standard Time):

Mon - Fri.— 8 A.M. to 7 P.M.

Saturday— 9 A.M. to 4 P.M.

IMPORTANT!

IF YOU NOTICE any freight damage or missing parts, either at the time of delivery or later during assembly, make sure that you put it in writing, within 15 days, and send your letter to the shipper to confirm that you intend to file a claim. Tell the driver, or inform the truck terminal, that you intend to file a written claim. They will advise you as to how to proceed. HOWEVER, if you have any problems with this procedure, please call us so that we can help you get satisfaction.

Section 1: Safety Instructions

Your Tiller has been carefully designed and assembled. However, as with any other piece of powered equipment, the operator must follow safe operating practices at all times. Failure to do so could result in personal injury or damage to the equipment or property.

Before assembling, operating or servicing the Tiller or its engine, carefully read and follow all of the safety instructions found in this Owner / Operator Manual, in the separate Engine Owner's Manual, and in any other literature you may receive. If you ever have any questions, please contact your local Authorized Dealer, or contact us at the Factory.

If you ever lend your machine to someone, make sure that he or she reads, understands, and follows the Safety Instructions. Always use this equipment carefully and keep safety in mind.



SAFETY ALERT SYMBOL. This symbol is used to alert you to important safety messages in this Manual and on decals which are on your tiller regarding potential hazards. When you see this symbol, carefully read and follow its safety message. Failure to do so can result in personal injury or property damage.

TRAINING

1. Carefully read this Owner/Operator Manual, the separate Engine Owner's Manual, and any other literature you may receive. Be thoroughly familiar with the controls and the proper use of the tiller/cultivator and its engine. Know how to stop the unit and disengage the controls quickly.
2. Never let children or uninstructed adults operate this equipment. Let adults operate the tiller only if instructed properly.
3. Keep the area of operation clear of all persons, particularly small children and pets.
4. Keep in mind that the operator or user is responsible for accidents or hazards occurring to other people, their property, and themselves.

PREPARATION

1. Thoroughly inspect the area where the tiller is to be used and remove all foreign objects.
2. Disengage all control levers before starting the engine.
3. Do not operate the tiller without wearing adequate outer garments. Avoid loose garments or jewelry that could get caught in moving parts of the tiller/cultivator or its engine.
4. Do not operate the tiller when barefoot or wearing sandals, sneakers, or light footwear. Wear footwear which grips well on slippery surfaces.
5. Do not till near underground electric cables, telephone lines, pipes or hoses. If in doubt, contact your telephone or utility company.
6. Handle fuel with care; it is highly flammable and its vapors are explosive. Follow these precautions:
 - a. Use an approved fuel container.
 - b. Add fuel before starting the engine. Never

remove the cap of the fuel tank or add fuel while the engine is running or when the engine is hot.

- c. Keep matches, cigarettes, cigars, pipes, open flames, and sparks away from the fuel tank and fuel container.
 - d. Fill fuel tank outdoors with extreme care. Never fill fuel tank indoors. Use a funnel or spout to prevent spillage.
 - e. Replace all fuel tank and container caps securely.
 - f. If fuel is spilled, do not attempt to start the engine, but move the machine away from the area of spillage and avoid creating any source of ignition until fuel vapors have dissipated.
7. Never make adjustments when engine is running (unless specifically recommended by the manufacturer).

OPERATION

1. The correct operator's position is when you are standing behind the handlebars, hands on handlebar grips, facing forward toward the engine. Do not leave this position while using the engine throttle lever.
2. Do not put hands or feet near or under rotating parts.
3. Exercise extreme caution when on or crossing gravel drives, walks, or roads. Stay alert for hidden hazards or traffic.
4. After striking a foreign object, stop the engine, disconnect the spark plug wire and prevent it from touching the spark plug, then carefully look

at the tiller for damage, and repair damage before restarting and operating the tiller.

5. Exercise caution to avoid slipping or falling.

6. If the machine should start to vibrate abnormally, stop the engine. Disconnect the spark plug wire and prevent it from touching the spark plug, and check immediately for the cause. Vibration is generally a warning of trouble.

7. Stop the engine, disconnect the spark plug wire and prevent it from touching the spark plug whenever you leave the equipment, before unclogging the tines, or when making any repairs, adjustments or inspections.

8. Before leaving the tiller unattended, always stop the engine. Disconnect the spark plug wire and prevent it from touching the spark plug.

9. Before cleaning, repairing, or inspecting, shut off engine and let all moving parts stop. Disconnect spark plug wire and prevent it from touching spark plug to prevent accidental starting.

10. Never operate tiller without proper guards, plates, or other protective safety devices in place.

11. Do not run the engine in an enclosed area. The exhaust fumes from the engine contain extremely dangerous carbon monoxide gas. Carbon monoxide gas is colorless, odorless, tasteless and deadly poisonous.

12. Keep children and pets away.

13. Be aware that the tiller may unexpectedly bounce upward or jump forward if the tines should strike extremely hardpacked soil, frozen ground, or buried obstacles such as large stones, roots, or stumps. If you are in doubt about the tilling conditions, always use the following operating precautions to assist you in maintaining control of the tiller:

a. Stand behind the tiller, using both hands on the handlebars. Relax your arms, but use a secure hand grip.

b. Start tilling at shallow depths, working grad-

ually deeper with each pass.

c. Clear the tilling area of all large stones, roots and other debris.

d. In an emergency, stop the tines by releasing the Engine Throttle Lever on the right handlebar. To stop the engine, move the Engine Ignition Switch to OFF.

14. Do not overload the tiller's capacity by attempting to till too deeply at too fast a rate.

15. Never operate the tiller on slippery surfaces. Look behind and use care when backing up.

16. Do not operate the tiller on a slope that is too steep for safety. When on slopes, slow down and make sure you have good footing.

17. Never allow bystanders near the unit.

18. Only use attachments and accessories that are factory-approved.

19. Never operate the tiller without good visibility or light.

20. Never operate the tiller if you are tired, or under the influence of alcohol, drugs or medication.

21. Do not tamper with the engine governor settings on the machine; the governor controls the maximum safe operating speed and protects the engine and all moving parts from damage caused by overspeed. Authorized service shall be sought if a problem exists.

22. Do not touch engine parts which may be hot from operation. Allow parts to cool before inspecting, cleaning or repairing.

23. Remember: You can stop the tines by releasing the Engine Throttle Lever. Move the Engine Ignition Switch to OFF to shut the engine off.

24. Never transport this machine when the engine is running. Shut the engine off before transporting the machine.

25. Terminals and non-insulated electrical parts shall be protected against shorting during normal servicing, refueling or lubrication.

MAINTENANCE AND STORAGE

1. Keep the tiller, attachments and accessories in safe working condition.

2. Check all nuts, bolts, and screws at frequent intervals for proper tightness to be sure the equipment is in safe working condition.

3. Never store the tiller with fuel in the fuel tank inside a building where fumes may reach an open flame or spark (hot water and space heaters, furnaces, clothes dryers, stoves, electric motors, etc.).

4. Allow the engine to cool before storing it.

5. To reduce the chances of a fire hazard, keep the engine free of grass, leaves, or excessive grease.

6. Store gasoline in a cool, well-ventilated area, safely away from any spark or flame-producing equipment. Store gasoline in an approved container, safely away from the reach of children.

7. Never perform maintenance while the engine is running or the spark plug wire is connected, except when specifically instructed to do so.

DECALS

If any of the decals below become illegible, damaged, or missing, order replacements immediately. See the Parts Ordering Information at the back of this Manual.

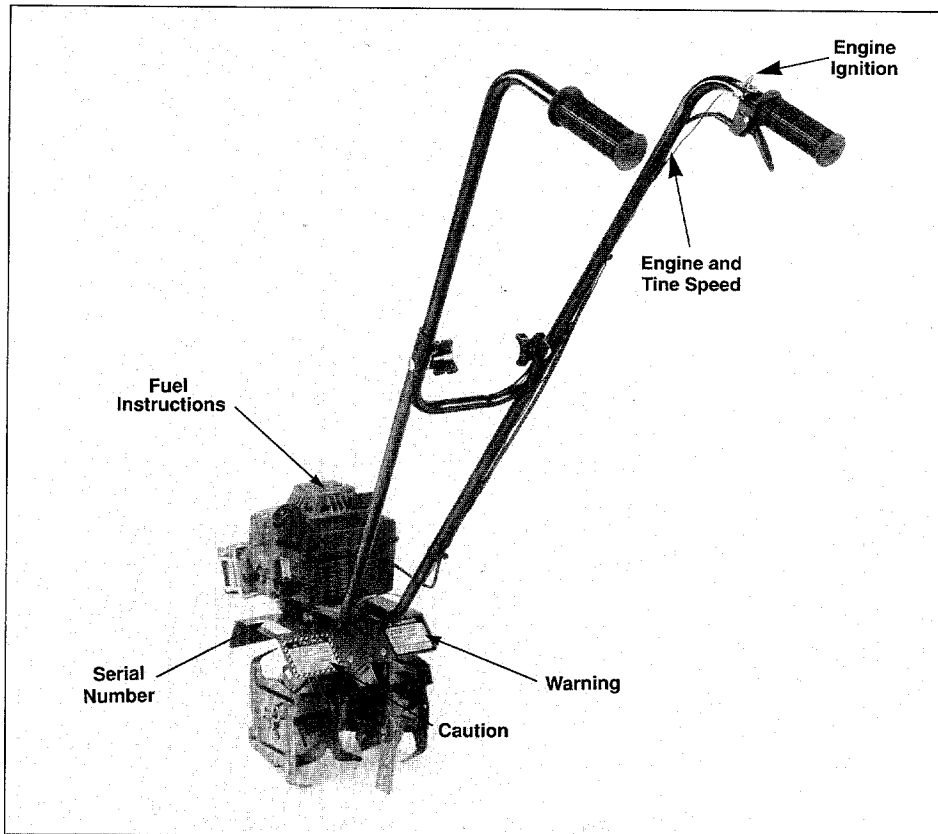

Photo 1: Decals

Section 2: Easy Assembly

Please follow the steps in this Section to assemble your tiller and prepare it for use. These steps will not take long and will assure correct assembly of your new tiller. We recommend you read this Section all the way through first. Then begin the assembly steps.

UNPACKING AND LOOSE PARTS

Your tiller was shipped fully assembled except for the parts shown in Photo 2. The small hardware items are inside a plastic bag.

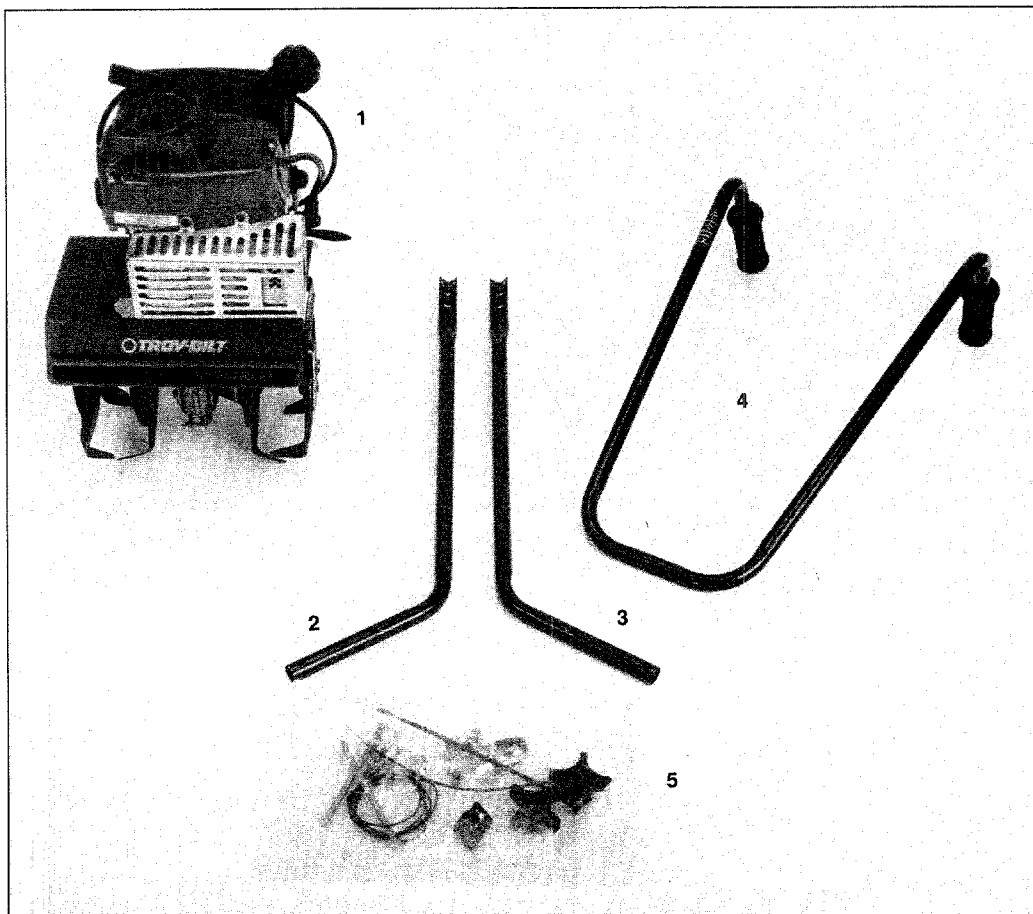

Photo 2: Contents of the shipping carton.

Carefully remove the contents of the shipping carton and compare the contents with the items shown in Photo 2 and listed below. If any items are damaged or missing, contact your local Authorized Dealer or our Technical Service Department.

1. The engine/tines/transmission assembly.
2. The lower right handlebar.
3. The lower left handlebar.
4. The upper handlebar.
5. The hardware bag, which contains:
 - (2) Handlebar Knobs
 - (1) Pan Head Phillips Screw, #10-16 x 1-1/2", Self-Tapping

- (2) Curved Head Carriage Bolts, 5/16"-18 x 2"
- (2) Hex Head Screws, 1/4"-20 x 5"
- (4) Flat Washers, 1/4"
- (2) Flat Washers, 5/16"
- (2) Locknuts, 1/4"-20
- (1) Rubber Spacer (rectangular shape)
- (2) Plastic Tie Straps
- (2) Tine Spacers (used when outer tines are removed for narrow tilling)
- (1) Engine Ignition Switch and Wire Assembly

ASSEMBLY STEPS

You'll need the following tools:

- Two 7/16" wrenches (a 7/16" socket with a socket extension and ratchet can be substituted for one of the 7/16" wrenches).
- One medium size Phillips head screwdriver.

1. Unwind the throttle cable from around the engine. Do not kink or severely bend the cable.
2. Place the engine/transmission assembly so it is resting on its "face" (the product name logo label is face down).
3. Position the round end of the lower left handlebar in the slot on the left side of the transmission – see Figure 3. (Look at the upper end of the handlebar and check that the groove in the half-round handlebar is facing inward. If not, install the other lower handlebar in the slot.)

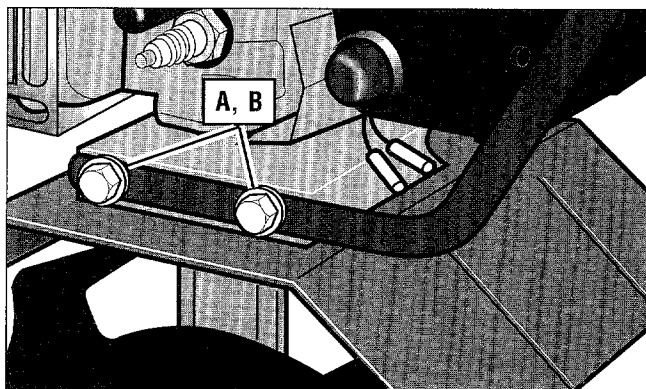

Figure 3: Attaching lower left handlebar.

4. Put a 1/4" flat washer (A, Figure 3) on the two 1/4"-20 x 5" long hex head screws (B) and insert the screws through the handlebar and out through the right side of the transmission.
5. Install the lower right handlebar over the ends of the screws – see Figure 4. Install a 1/4" flat washer (C) and locknut (D) on each screw.
6. Slowly and evenly tighten the two screws and locknuts. Snug the nuts down, but do not over-tighten them.
7. Place the upper handlebar between the top ends of the lower handlebars (rubber handlebar grips face to rear).

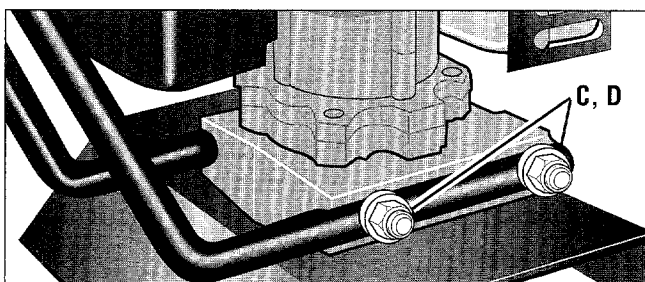

Figure 4: Install lower right handlebar.

8. Align the hole in the left upper handlebar with one of the two rectangular holes in the left lower handlebar (the rectangular holes allow the handlebar to be adjusted higher or lower). From the outside, insert a 5/16"-18 x 2" long curved head carriage bolt (E, Figure 5) through the holes.
9. Put a 5/16" flat washer (F) on the bolt and loosely thread on a handlebar knob (G). See Figure 5.
10. Repeat steps 8 and 9 for the right side.
11. Tighten both handlebar knobs.

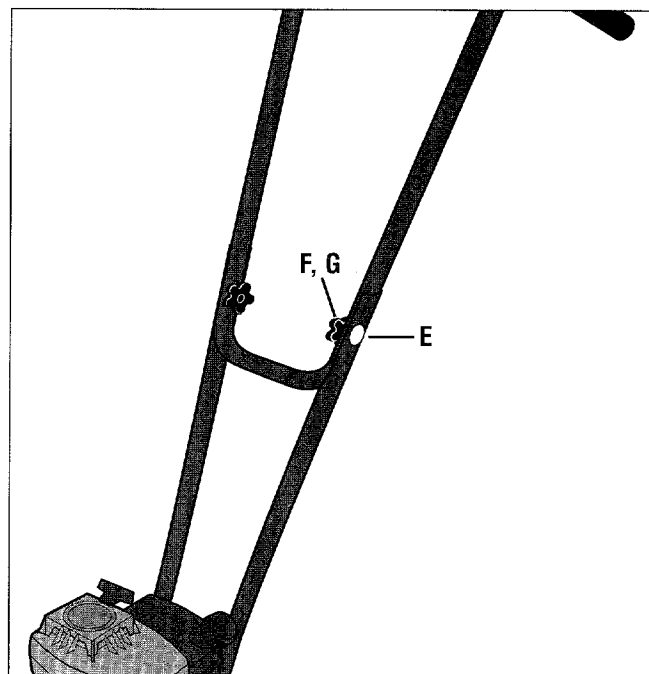

Figure 5: Attach upper handlebar to lower handlebars (viewed from front of engine).

12. Insert the #10-16 x 1-1/2" long pan head Phillips screw (H, Figure 6) down through the hole in the engine ignition On/Off Switch bracket (I). Next, insert the screw through the hole in front of the right side handlebar grip. Note that the switch, wires and bracket are positioned to the inside edge of the handlebar.
13. Install the rectangular rubber spacer (J, Figure 6) on the screw and turn the spacer so that its long end points toward the grip.
14. Align the hole in the engine throttle lever assembly (K) with the end of the screw.
15. Hold the throttle lever assembly in place and use a Phillips head screwdriver to firmly tighten the screw.

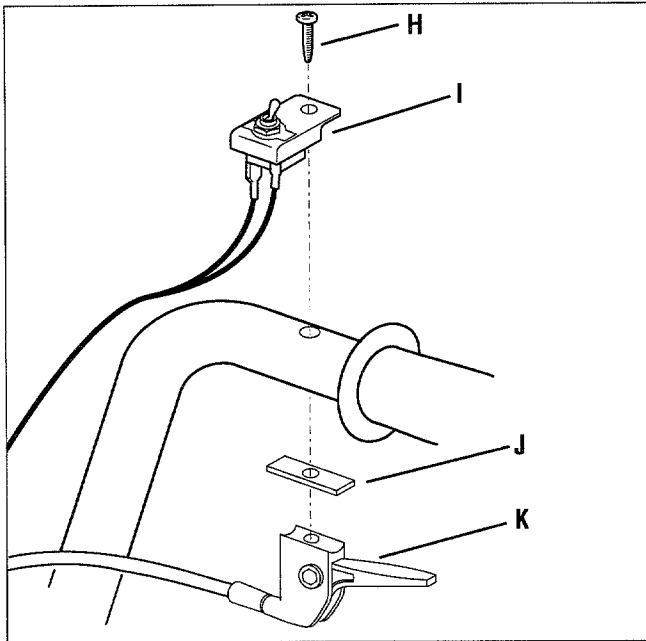

Figure 6: Installing engine On/Off switch and throttle lever assembly on right handlebar.

16. There are two wires attached to the On/Off switch assembly. See Figure 7. Each wire has a different colored connector at the other end.

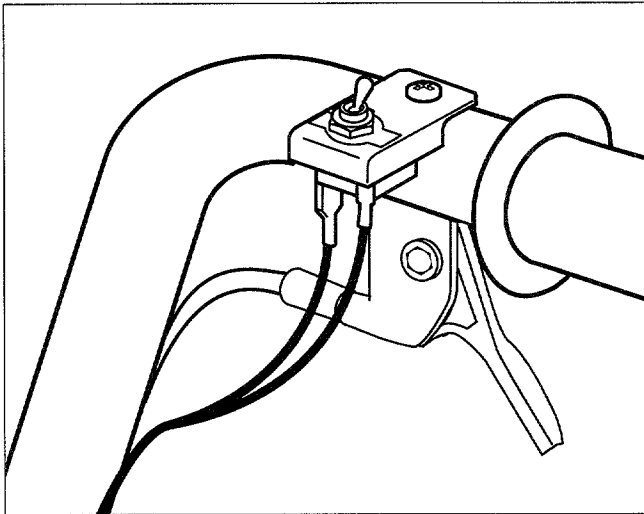

Figure 7: Two wires are attached to the On/Off switch assembly.

17. Connect these two wires to the two loose wires that lead from the engine (see arrow in Figure 8). Snap together the two sets of wires having the same connector colors (red to red and white to white).

18. Secure the throttle cable and the On/Off switch wires to the lower and upper handlebars with two plastic ties (Figure 9). The serrated side of the ties should be on the inside when you loop the tie around the handlebar, wire and throttle cable. Tighten the tie by pulling on its loose end. Snip off any excess tie length.

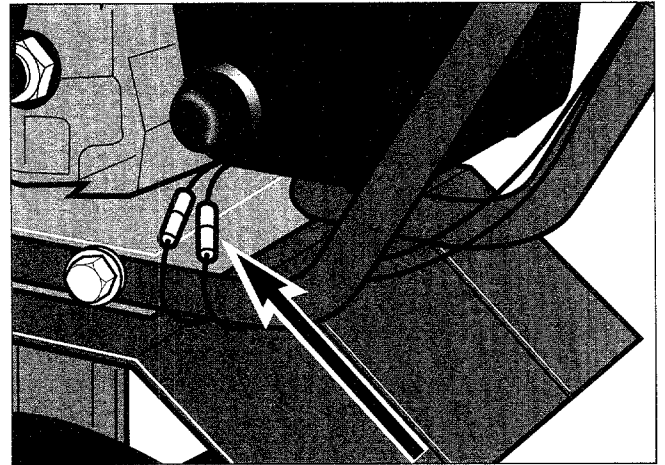

Figure 8: Connect the two sets of wires having the same connector colors.

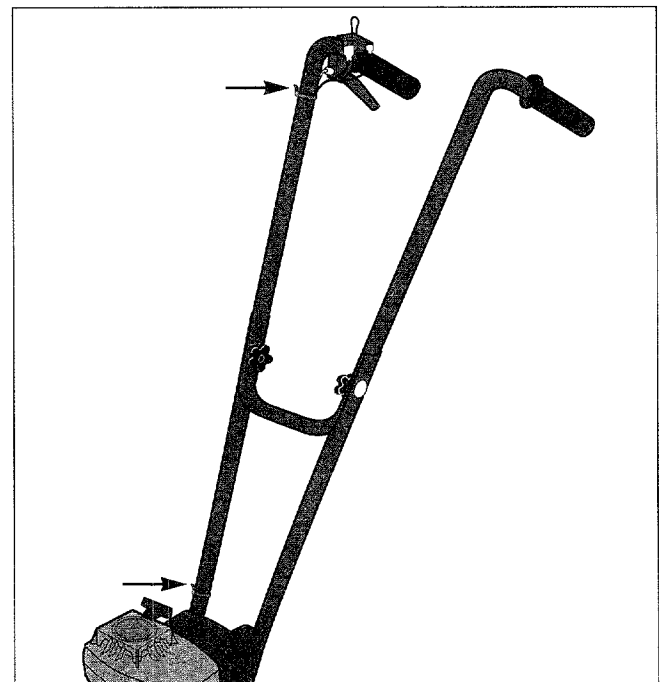

Figure 9: Install plastic ties.

19. Inspect the machine and tighten any loose hardware.

IMPORTANT: Do not tighten or adjust the engine governor screw shown in Figure 9A. It is factory-adjusted for proper engine operation!

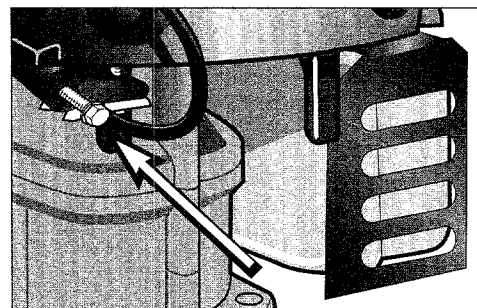

Figure 9A: Do not adjust or tighten factory-set governor speed screw (see arrow).

Section 3: Operation

Your equipment is now assembled and ready to be serviced with the correct fuel/oil mixture.

THE GASOLINE / TWO-CYCLE ENGINE OIL MIXTURE

Since your tiller has a Tecumseh two cycle ("two-stroke") engine, you **MUST** mix together a quality two-cycle oil with gasoline. The mixture is 24 parts gasoline to 1 part two-cycle oil. If you do not do this, the engine will seize up from a lack of lubrication. (This is similar to allowing your car's engine to run out of oil.)

WARNING

Gasoline is highly flammable. Keep gasoline away from possible ignition sources.

Do not smoke while mixing the fuel/oil or when filling the gasoline tank.

Failure to follow these precautions could result in the fuel igniting, resulting in personal injury or property damage.

WARNING

Never mix gasoline and two-cycle oil directly in the machine's gas tank.

Use the proper fuel/oil mix.

Read the fuel/oil mixing instructions in this Manual and on the engine. Disregard any conflicting instructions on pre-mixed fuel/oil containers. Always use the proper oil.

Use fresh, clean, unleaded regular gasoline (only use unleaded premium gasoline if unleaded regular is not available). **DO NOT USE** gasoline containing Methanol (wood alcohol). See the separate Engine Owner's Manual for instructions regarding the use of gasoline containing ethanol or grain alcohol.

Use a clean, high quality two-cycle oil. Do not use a multi-viscosity two-cycle engine oil. Do not use regular engine oil. These types of oil may not lubricate the engine properly and may foul the spark plug.

NOTE—

Use only clean two-cycle oil and gasoline. Store fuel mixture in an approved, clean container.

Use a clean funnel to fill the tank.

To Mix Oil and Gasoline

To mix: first fill a clean container with one-quarter of the amount of gasoline you will be mixing. Then add **ALL** of the two-cycle oil required for the entire amount of fuel you're mixing. Mix this thoroughly. Then add the remaining three-quarter's of the amount of gasoline.

FUEL MIX CHART					
Mixture Ratio— 24:1					
U.S.		IMPERIAL		S.I.(Metric)	
Gas	Oil to Add	Gas	Oil to Add	Petrol	Oil to Add
1 gal	5 oz.	1 gal	6 oz	4 liter	.167 liter
2 gal	11 oz	2 gal	13 oz	8 liter	.333 liter

To fill the fuel tank on the engine: first wait until the engine cools. Then insert a clean funnel into the fuel tank. Slowly pour the fuel/oil mixture into the fuel tank, being careful not to overfill the fuel tank. (Fill the fuel tank up to, but no higher than, 1/2 inch from the top to allow room for gasoline expansion.)

STARTING AND STOPPING

Starting the Engine

1. Make sure the spark plug wire is connected.
2. Turn the engine ignition On/Off Switch to ON. NOTE: The On/Off switch wire must be securely connected at both ends. Check regularly to see that this wire is firmly attached to its connecting points.
3. Determine which of the following three starting conditions applies to you:

Priming When First Time Starting:

Use this priming method to start a new engine for the first time, or after running out of fuel, or after extended storage. Prime the engine using High-Volume priming (see "A", Figure 10). Use your thumb and forefinger to squeeze side of primer bulb that is in line with the light-colored rib on the primer body. As fuel enters the priming system, the priming action will feel more firm. Squeeze the primer bulb 6 times (this process removes air from the priming system).

Priming When Cold Starting:

To prime the engine after it has been sitting idle or has been in brief storage and has fuel in the tank, use the Standard Volume method (see "B", Figure 10). Push in top of primer bulb twice if above 55°F, or three times if below 55°F.

When Warm Starting:

Do not use the primer bulb to restart the engine after it has been stopped after running, still has fuel in the tank, and has not cooled completely.

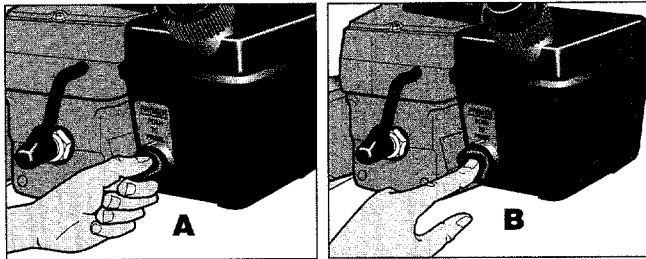

Figure 10: Select the right fuel priming technique: High Volume (A) or Standard Volume (B).

! WARNING

Do not touch the Throttle Control Lever while starting the engine.

The tines may propel the machine forward if the engine speed is advanced from idle.

Failure to follow these instructions can result in personal injury or property damage.

4. Stabilize the tiller with your left hand on its right handlebar so it doesn't fall over. Keep your feet positioned safely away from the tines.

5. To start the engine, slowly pull out the recoil start rope until you feel resistance. Let the rope rewind. Then, with a quick arm motion, pull the rope all the way out, up to 10 times. Let the rope rewind slowly. Allow the engine to warm up for several seconds. If the engine fails to start or to continue running, push in the primer bulb two times. Grasp the start rope and pull with a rapid, full arm stroke, up to 10 times.

Troubleshooting: Push the primer bulb in two more times. Using a rapid, full stroke, pull out the starter rope up to 10 times. If engine still does not start, wait 15 minutes. Do not prime engine further. Grasp start rope and pull with a rapid, full stroke up to 10 times.



Photo 10A: Starting the engine.



Figure 11: Operating position. Do not use engine throttle lever unless you are in this position.

! WARNING

The muffler and surrounding areas become very hot during engine operation.

Avoid contact with this area. Failure to comply could result in personal injury.

Stopping

To stop the engine, move the engine On/Off switch to its OFF position.

NOTE:

For the On/Off switch to work properly, the On/Off wires must be securely connected at both ends. Check regularly to see that the wires are firmly connected.

TILLING AND CULTIVATING

! WARNING

NEVER transport tiller when engine is on.

Failure to follow these instructions could result in personal injury or property damage.

1. Move the tiller to the work area.
2. Make sure that the engine On/Off switch is in the ON position.
3. Start the engine. **Assume the operator's position behind the handlebars.** Tilt the tiller back on its drag stake until the tines are off the ground. Squeeze the throttle lever and then release it. The engine should speed up and then return to idle speed. The tines should stop rotating or they may rotate very slowly. Lowering them back to the ground should stop any rotation.

NOTE: If the tines continue to rotate when the engine is idling, either the idle speed is too high or the centrifugal clutch is malfunctioning. If this occurs, contact your local authorized Tecumseh Service Dealer.

4. Tilt the tiller back so its tines are clear of the ground. Squeeze the throttle lever.
5. Lower the tines to begin digging. When the tines contact the ground, the cultivator may tend to "walk" forward. Firmly hold the handlebars to prevent the tiller from moving forward too fast and to give the rotating tines sufficient time to dig into the earth.

6. If you need to make any adjustments to the tilling depth:

- a. Turn the engine OFF. Disconnect the spark plug wire.
- b. Remove the hairpin cotter and the clevis pin from the depth stake bracket.
- c. Move the depth stake down for deeper tilling and cultivating, or up for shallower work.
- d. Reinsert the clevis pin through the aligned holes (in depth stake and depth stake bracket), and secure it in place with the hairpin cotter.

GENERAL RECOMMENDATIONS

Avoid tilling and cultivating in soil that is too dusty or too wet. Neither of these soil conditions lend themselves to proper cultivation.

If the tiller/cultivator tends to stay in one spot and just dig a hole instead of moving forward, move the handlebars from side to side to start the machine moving forward again.

When cultivating to get rid of unwanted plants, it is best to use a shallower setting to prevent bringing any weed seeds to the surface.

If you need to cultivate between very closely spaced plants, you can remove the outer tines as instructed in Section 4. This will give you a cultivating width of approximately 6 inches.

After you've finished cultivating, check the tines for any tangling. Stop the engine and disconnect the spark plug wire before untangling the tines. Be sure to reinstall the tines in the same position from which you removed them. If you reinstall the tines incorrectly, they will not work as well and will make the equipment jump.

To till deeply, hold the tiller/cultivator in one spot and allow it to dig as deep as you want.

The drag stake can be removed to allow the tiller/cultivator to dig to maximum depth.

If a rock should get stuck between the tines and the hood, you can remove the drag stake and use it to pry the rock loose. You can also use a block of wood and a hammer to remove the rock. The tines only turn in one direction (clockwise as viewed from the right side). Do not attempt to force them to turn the opposite way.

IMPORTANT: Running the engine when the tines are immobilized by a wedged rock or root can burn out the clutch. Always remove an obstruction binding the tines before damage occurs.

IMPORTANT: Your unit has a centrifugal clutch which is designed to operate within a specific RPM range of the engine. If you bog your engine down (below this range), the clutch will disengage and the tines will stop turning.

TIPS AND TECHNIQUES

Cultivating and Weeding

For effective weed control: prepare the ground thoroughly, as early as you can, and till it again several times before you plant. Each time you do this, you bring buried weed seeds to the surface where they begin to sprout and are killed next time you till. Then, just before you plant, do one last *shallow* tilling to destroy the latest batch of weed sprouts. From then on, keep all cultivation shallow, so buried weed seeds stay buried too deep to germinate.

Your tiller is ideal for this kind of shallow cultivating, and the work goes quickly because you only need to dig an inch or so deep. Some other tips:

- Set the depth stake with its sloped edge forward (point backward) to minimize tangling on weeds and to speed up cultivating. Don't set it too deep; cultivating must be shallow.
- For weeding and cultivating in very tight spots, you can remove the outer tines and work with just the inner tines which provide a 6" tilling width. In these tight situations, you may want to remove the depth stake too.

- The machine can be "steered" by tipping it slightly to either the left or the right.
- To catch weeds growing very close to more mature garden crops or plants, you can pull the tiller backward so the tines lift up the plant leaves. This allows close weeding without damage to the foliage.
- When cultivating around short ornamentals or flowers, place the machine on the *far side* of the plant so the earth is moved toward it, rather than stripped away from its roots.



Photo 11A

Some Special Techniques

Your handy tiller can do some impressive tricks for you after you've had a fair bit of practice with it. Here are a few:

- To make a furrow, remove the two outer tine gangs and replace them with the short tine spacers. Also remove the depth stake. Use a high engine throttle setting and pull the machine slowly straight backward, allowing earth to spill out on each side. You'll have a fine furrow.



Photo 11B

- For hills and raised beds, keep all the tines in place and pull the machine backward at a tilt, so you "hill" up the earth on one side.
- You don't have to carry your tiller across the lawn to a work area. If you prefer, you can start the engine and "walk" the machine lightly over the grass. Keep the engine speed as low as possible—just high enough to keep the tines rotating at your walking pace, or the tines will try to dig into the lawn.

Tilling Sod

- Set the depth stake with its point facing forward and adjust it deeply enough so the machine will



Photo 11C

pull itself along at a steady pace.

If you set the stake too deep, the machine won't pull itself at all; if too shallow, it will want to move ahead too quickly. Keep in mind that one depth stake height adjustment either way can make a big difference. Take a little time and experiment. Different soils and tilling depths require different stake adjustments.

- Occasionally, "sweeping" the tiller from side to side is helpful when the going is tough. This lets the tines undercut roots and stones, leaving a completely tilled path. This can also be accomplished with multiple passes (normally required when breaking sod with a powered tiller).

Tilling Seedbeds

Your tiller will also do a nice job of digging up a small plot of soil for planting. This is usually easier than tilling sod. Once again, set the stake with the point facing forward and take time to get the depth adjusted correctly.

- Here's a trick to smooth the bed for seeding after it's well-tilled: Hold the machine level and pull it quickly backward over the ground like a large hoe. The slower you work and the higher the engine speed, the more earth you'll move, so just use a quick motion and you'll reduce the need for raking.

Tilling in Stony Soil

Your tiller was specifically designed to have a very small center tine gap, allowing it to weed more effectively and to mix the soil more thoroughly.

However, when tilling deeply in stony soil, you'll find that stones can frequently lodge between the tines and tiller hood, stopping tine motion. **If a rock jam occurs, shut off the engine and disconnect the spark plug wire.** Take off the tine gangs to free the lodged stone. If this doesn't remove the jam, pry out the rock by using a block of wood and a hammer. (Wear safety glasses if you need to do this.) Don't try to rotate the tines backward, and don't wear out the clutch trying to drive the jammed tines forward using engine power. Once loose, toss the stone away from the garden area.

A Special Tine Pattern For Stony Soils

If you encounter frequent rock jams in the tines when working in very stony soils, here's a simple change in the tine pattern that will generally minimize the problem.

Wearing heavy gloves, remount the four tine gangs in the following order: move the inner-left tine gang to the inner-right position, and the inner-right gang to the inner-left position. Keep the outer tine gangs as is. Remember—the curved tine edges enter the soil first!

Remounting the tine gangs takes just a couple of minutes. The Figures to the right show the normal tine pattern where there is a narrow gap between the center (inner) tines, and the special stony soil tine pattern where the inner tine gangs have been swapped in position. The stony patterns creates a wider gap between the inner tine gangs — rocks are much less likely to become lodged between them and the tine hood.

IMPORTANT: Remember that when you remount the tines on the tine shaft, they must be turned in the direction that allows the curved portions of the blades to enter the soil first! Don't turn the tines so they face backwards or tilling will be very difficult.

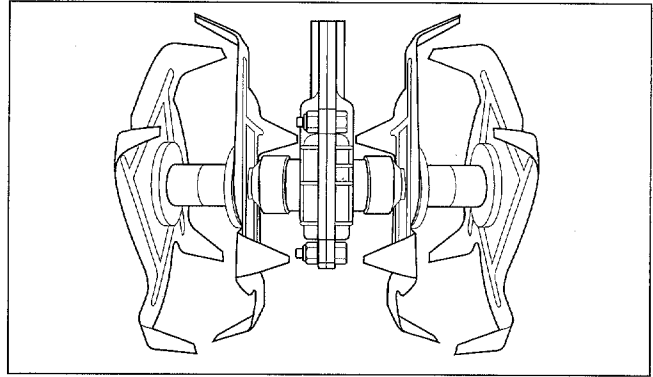

Figure 11D: Normal tine gang pattern.

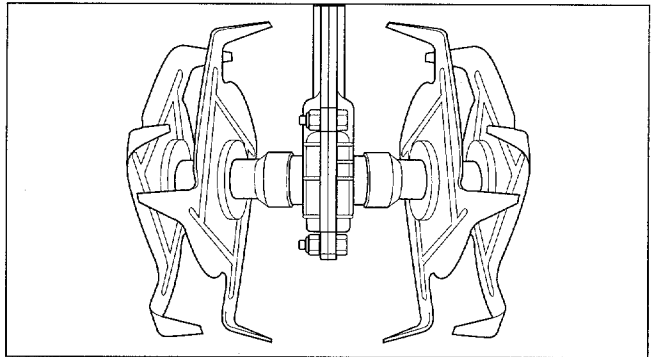

Figure 11E: Tine gang pattern for very stony soil.

Section 4: Maintenance

ENGINE LUBRICATION

The engine on your tiller is a two-cycle (“two-stroke”) engine. Engine lubrication is provided by mixing the proper type and amount of two-cycle oil with the gasoline. Refer to “The Gasoline/Two-Cycle Engine Oil Mixture” for correct proportions and mixing instructions.

TRANSMISSION LUBRICATION

The transmission was factory-lubricated with high-quality grease and should not require any additional regular lubrication.

However, you should *check* for sufficient lubricant after the initial five hours of operation, and every twenty-five operating hours afterward.

If needed, use grease that is a high quality, automotive petroleum-base grease usually available at most hardware or auto parts stores.

To check the transmission:

1. Lay the machine on the left side so the tine shaft is vertical.
2. Remove both right-side tines (see “Tine Removal” this Section).
3. Clean any dirt or debris away from the transmission so none will enter the housing.
4. Remove all three threaded plugs from the right

side of the transmission. See Figure 12 for their locations. Lubricant should be visible in the top two holes. If so, replace the three plugs securely. If lubricant is needed, see the following steps.

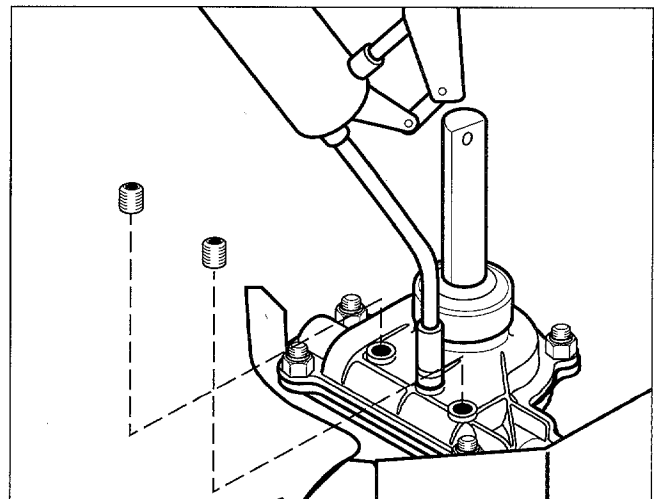

Figure 12: Use grease gun to fill transmission.

To lubricate the transmission:

5. Place the nozzle of a grease gun on the rim of the middle hole. Push the nozzle firmly up against the opening.

6. Apply grease until it begins to come out of the bottom hole. Replace the bottom plug securely. Then apply grease to the top plug hole. Add until it begins to come out of the middle hole. Reinstall the plugs in the middle and top holes.

7. Reinstall the right-side tines. Before reinstalling the tines, use a fine grade of sandpaper to clean any rust off the tine shaft. Then coat the tine shaft with a few drops of oil or anti-seize compound to make future tine removal easier.

ENGINE AIR CLEANER

WARNING

The temperature of the muffler and adjacent areas on the engine may exceed 150°F (65°C). Avoid these areas during maintenance. Disconnect the spark plug wire and keep it away from the spark plug prior to any maintenance.

Service the air filters every three (3) months or every 25 operating hours. Service daily if used in extremely dusty conditions. The filter assembly has one thin flocked filter and one thick foam filter.

IMPORTANT: Never run engine without air filter assembly properly installed.

To Remove and Inspect Air Filter Assembly:

1. Loosen both cover screws and remove cover (A, Figure 13) and screws.
2. Remove the outer, flocked filter (B).
3. Remove the thick foam filter (C).
4. Inspect the filters for discoloration or dirt accumulation. If either is present, service the filters.
5. Thoroughly clean inside of cover and body.

To Service Thick Foam Filter:

1. Wash in a water and detergent solution and squeeze (do not twist) until all dirt is removed.
2. Rinse thoroughly in clear water. Then, wrap in a clean cloth and squeeze until dry.
3. Saturate with motor oil and squeeze (do not twist) to distribute oil and remove excess oil.

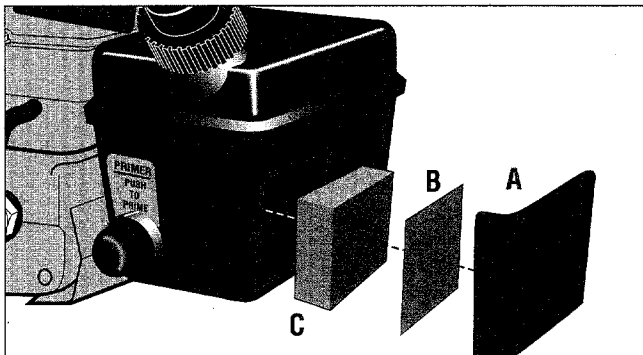

Figure 13: The air cleaner assembly.

To Service Thin Flocked Filter:

1. Wash filter in a water and detergent solution.
2. Rinse thoroughly in clear water, then air dry.
3. Reassemble filter as shown in Figure 13. Do not overtighten cover screws.

CARBURETOR ADJUSTMENT

WARNING

The temperature of the muffler and adjacent areas on the engine may exceed 150°F (65°C). Avoid these areas during maintenance. Remove the spark plug lead and ground the lead to the engine to prevent accidental starts and fires. Failure to do this could cause bodily harm.

IMPORTANT: Never tamper with the engine governor which is factory-set for the proper engine speed. Overspeeding the engine above the factory high-speed setting can be dangerous.

Carburetor Adjustment If Engine Runs Poorly

If the engine is running poorly or has low power under tilling conditions, an idle mixture screw adjustment to the carburetor may solve the problem. However, first inspect and service the spark plug and the air filter before making a carburetor adjustment. If the engine continues to run poorly (and the fuel mixture is fresh), proceed to the carburetor adjustment instructions below.

This factory-engineered instruction has been designed to provide continued optimum engine operating performance after the engine break-in period, which is usually 5 to 10 hours. The adjustment, when properly performed as described below, will not void the engine warranty. All that is needed is a common screwdriver. If you prefer, contact an authorized Tecumseh Service Dealer for a carburetor adjustment.

Prior to Carburetor Adjustment:

1. Let the engine cool for 30 minutes before continuing.
2. From the operator's position behind the handlebars, lay the machine down on its left side (muffler side).

Carburetor Adjustment:

1. Locate the carburetor idle mixture screw (see Figure 14). It is directly under the air filter and is black. **DO NOT ADJUST THE SILVER-COLORED SCREW.**
2. Turn the idle mixture screw 1/16 of a turn clockwise.

3. Return the tiller to its normal upright operating position and reconnect the spark plug lead.
4. If the engine continues to run poorly, please contact an authorized Tecumseh Service Dealer.

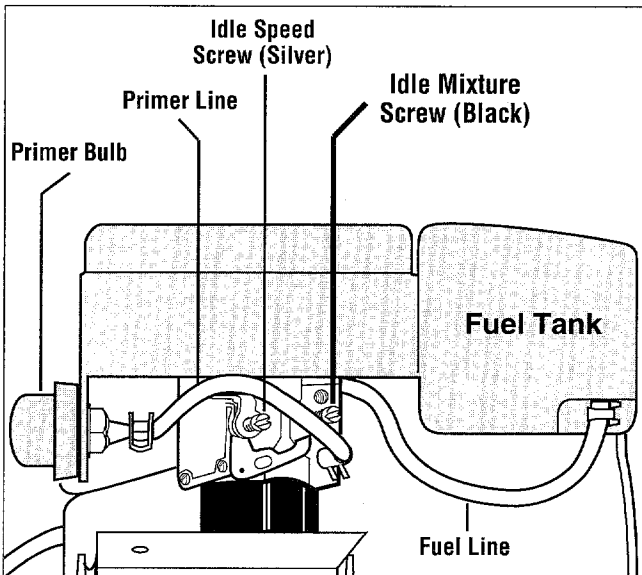

Figure 14: Idle mixture screw can be adjusted.

COOLING SYSTEM

Frequently remove debris from the engine cooling fins, around the air intake screen, and levers and linkage. This will help to ensure adequate cooling and correct engine speed.

SPARK PLUG

Inspect the spark plug once yearly or every 75 operating hours. The gap should be set at .030". Refer to the Engine Owner's Manual for cleaning and replacement information.

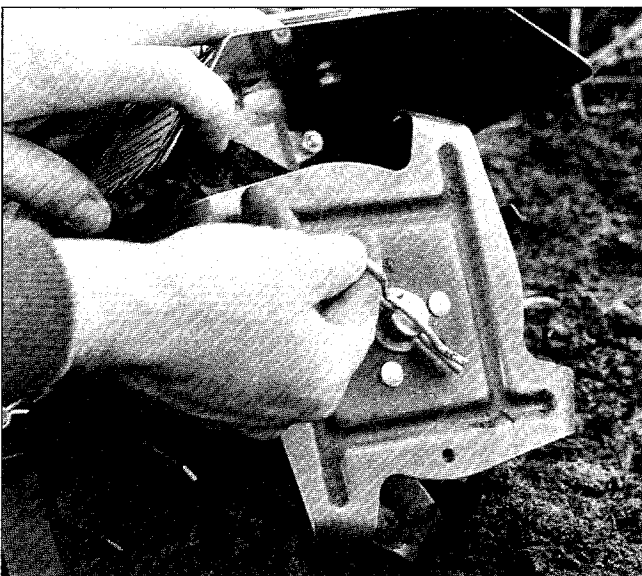

Photo 15: Removing the hairpin cotter.

TINE REMOVAL & INSTALLATION

! WARNING

Worn tines may be sharp. Wear heavy gloves when removing, handling, or reinstalling tines to prevent personal injury.

IMPORTANT: The four tines are not interchangeable. They must be reinstalled in the same positions and their cutting edges must face forward. If replacing tines due to wear, replace all four as a set, rather than replacing a single, worn tine.

To be sure of reinstalling the tines in the correct order, mark the tines as follows: Disconnect the spark plug wire. Use a sharp nail or awl to scratch the tine location on the tine (Outer L/H, Inner L/H, Outer R/H, and Inner R/H).

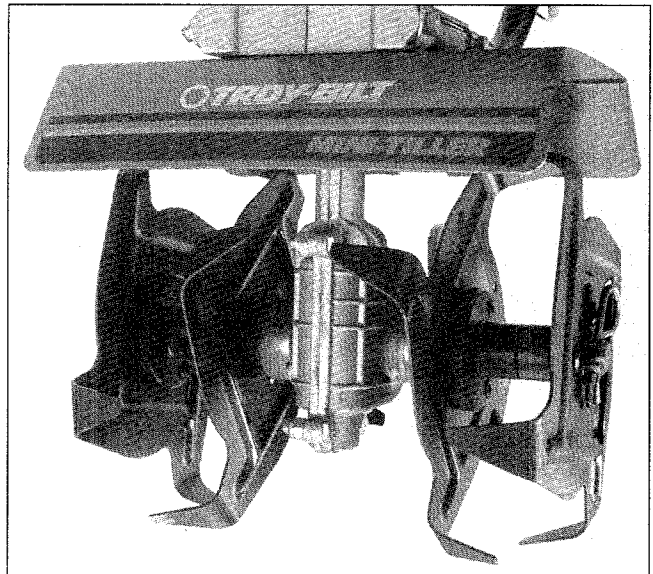

Photo 16: The correct position of the tines.

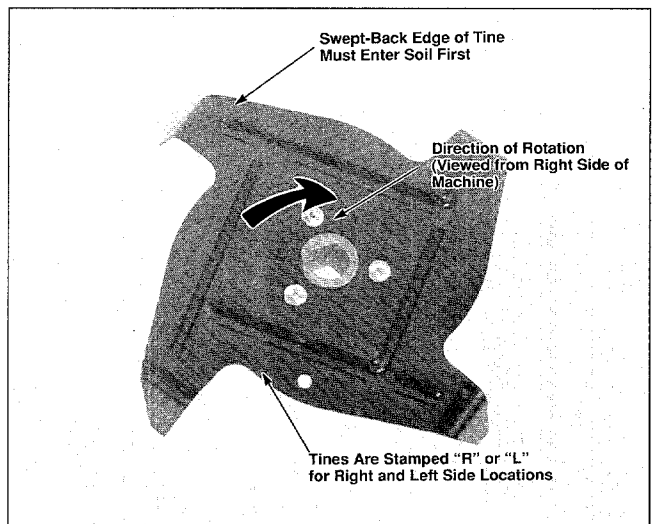

Photo 17: Side view of a tine.

A. To remove the tines:

1. Remove the hairpin cotter from the tine shaft (Photo 15), and remove the two tines. Store the hairpin cotter with the tines or reinsert it in the tine shaft.

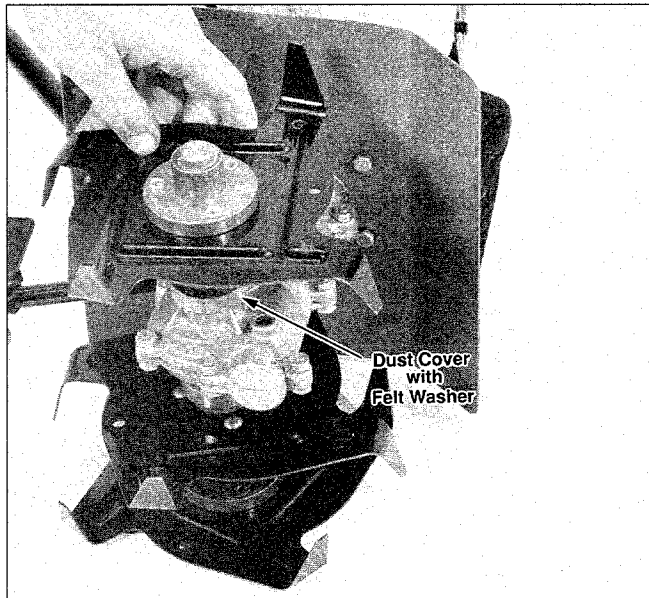

Photo 18: Installing an inner tine.

2. Remove the tines from the other tine shaft.

B. To reinstall the tines:

When reinstalling the tines, refer to Photo 16 for the correct location of each tine.

1. Check that the dust cover and felt washer (underneath the dust cover) are in place on the tine shaft, against the side of the transmission. The set screws on the dust covers should be tight and should not allow the dust covers to move.

Clean the tine shafts and use fine-grade sandpaper to remove any rust or burrs. Apply a thin coat of oil to the tine shafts to make future tine removal easier.

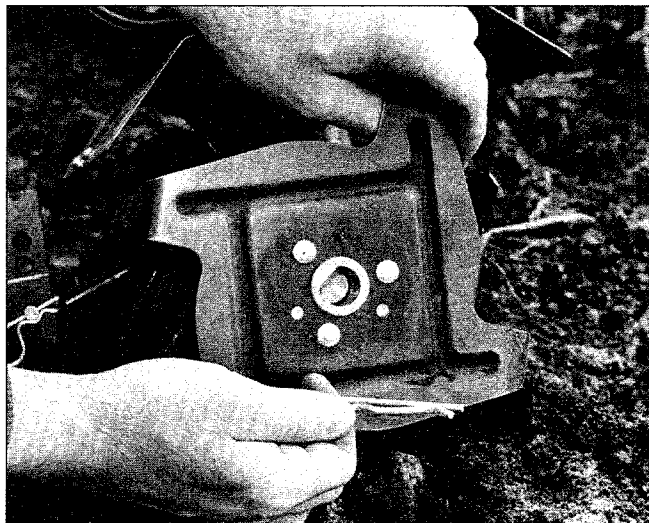

Photo 19: Installing an outer tine.

2. Slide the inner tine over the tine shaft (Photo 18, followed by the outer tine (Photo 19).

3. Secure the tines with the hairpin cotter in the outer hole in the tine shaft. It is easier to install the hairpin cotter by inserting it through the hole in the tine shaft 90° from its installed position and then turning it so it lies flat against the outer tine.

4. Install the tines on the other tine shaft.

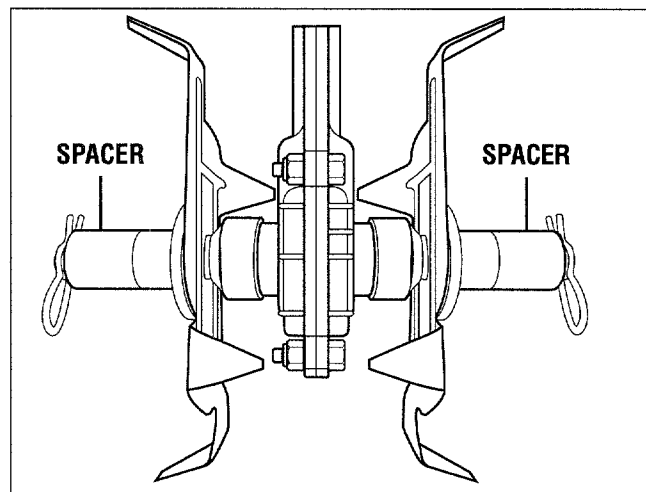

Figure 20: Outer tines off for narrow cultivating.

NARROW CULTIVATING

The two outer tines can be removed for a narrower tilling or cultivating width of approximately 6 inches (Figure 20).

To do this, simply remove the outer tines (see previous instructions). Then place a tine spacer (included with your machine) over the tine shaft. Secure the spacer in place with the hairpin cotter.

STORAGE

! WARNING

Never store the tiller when there is gasoline in the fuel tank.

Never place the tiller near any source of sparks or open flame (such as a hot water heater, space heater or clothes dryer).

Failure to comply can lead to serious personal injury or property damage.

To prepare your tiller for extended storage:

1. Prepare the engine for storage by following the "STORAGE" instructions in the separate Engine Owner's Manual.

2. Remove the tines and clean all soil and debris away from the dust covers and the tine shaft. Lubricate the tine shaft

3. Allow the engine to cool and then cover the engine and store the machine in a dry, sheltered location.

Replacement Parts – Figure 1

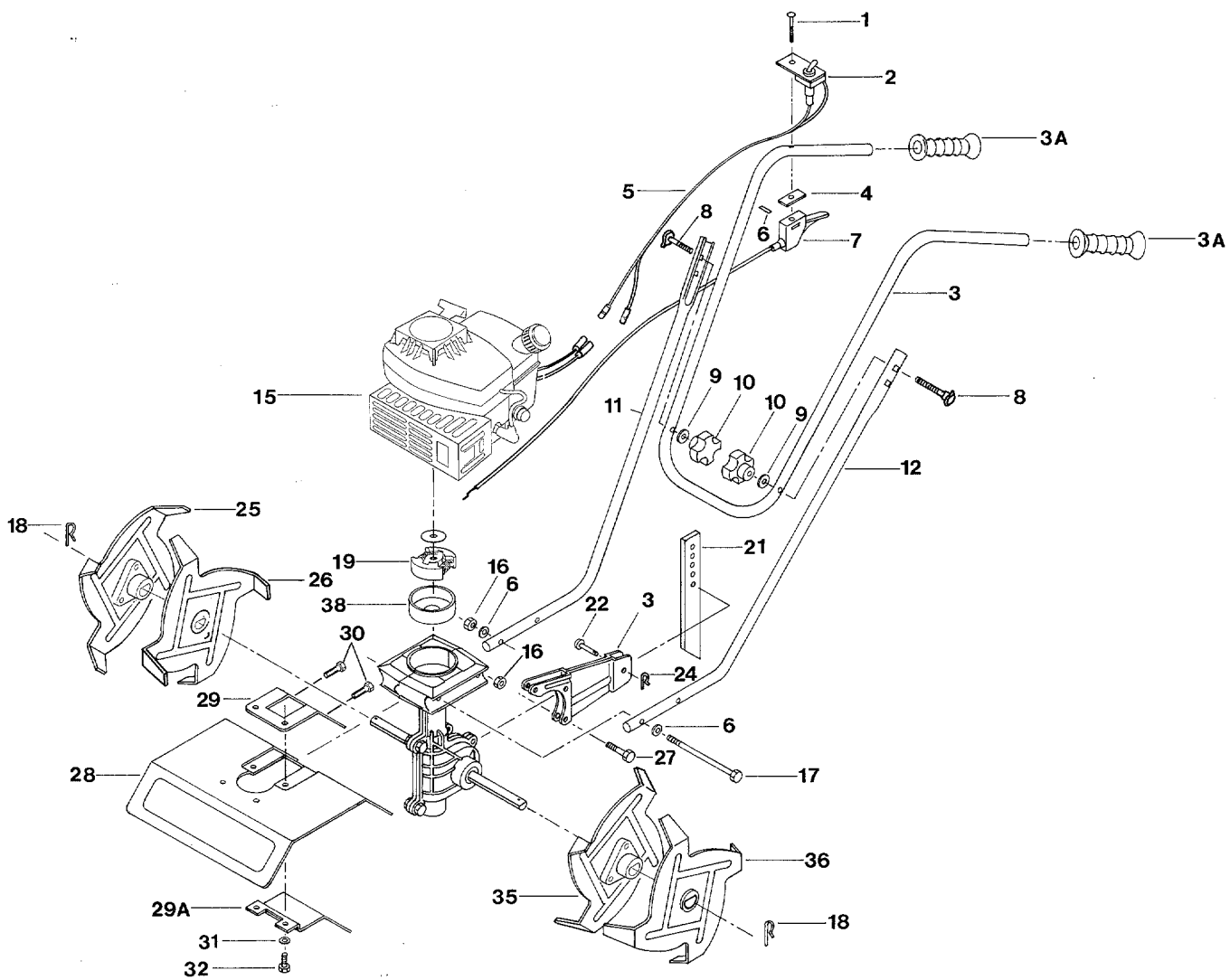

PARTS ORDERING INFORMATION

If you should ever need any replacement parts for your unit, please use the exploded parts illustrations and parts listings on Pages 20-22 to determine which parts you'll need to order.

You may order replacement parts from a local Authorized Dealer or from the Factory.

When ordering parts, the following information is required:

1. The Serial Number of your unit.
2. The Part Number of the part.
3. The Description of the part.
4. The Quantity needed.

Replacement Parts – Figure 1

REF No.	PART No.	DESCRIPTION	QTY.
1	1750608*	Screw, Pan hd., #10-16 x 1-1/2 ...	1
2	11983718	Switch, Engine Ignition	1
	1981012001	Bracket, Switch	1
3	1981046	Upper Handlebar Assembly. Incl. two grips and two decals ...	1
3A	1983728	Grip, Handlebar	2
4	1983649	Spacer, Rubber	1
5	1766998	Ignition Wire, Engine "On/Off"	1
6	1107381	Washer, Flat, 1/4	4
7	1986201	Throttle Lever & Cable Assembly. .	1
8	1731025	Bolt, Carriage, 5/16-18 x 2	2
9	1107382	Washer, Flat, 5/16 I.D.	2
10	1763767	Knob, Handlebar	2
11	1984509001	Lower Handlebar, Right	1
12	1984510001	Lower Handlebar, Left	1
13	---	This Ref. No. Not Used	
14	---	This Ref. No. Not Used	
15	---	Engine, 2-Cycle – See Note below.	1
16	1817146	Locknut, 1/4-20*	10
17	1983663	Bolt, Hex hd., 1/4-20 x 5*	2
18	1185590	Cotter, Hairpin	2
19	1909487	Rotor, Clutch	1
20	---	This Ref. No. Not Used	
21	1981014001	Drag Stake	1
22	1983723	Pin, Clevis, 5/16 x 7/8	1
23	1981010001	Bracket, Drag Stake	1
24	1703011	Cotter, Hairpin	1
25	1984430	Tine, Outer, Right Side	1
26	1984429	Tine, Inner, Right Side	1
27	1100069	Bolt, Hex hd., 1/4-20 x 1*	3
28	1904124	Tine Cover. Incl. decals	1
29	1981022010	Rear Plate, Tine Cover	1
29A	1981018010	Shield, Rock	1
30	1983662	Screw, Self-Tapping, #10-32 x 1/2	2
31	1100241	Lockwasher, 1/4	4
32	1100807	Bolt, Hex hd., 1/4-20 x 2, Grade 5.	4
33	---	This Ref. No. Not Used	
34	---	This Ref. No. Not Used	
35	1984427	Tine, Inner, Left Side	1
36	1984428	Tine, Outer, Left Side	1
37	---	This Ref. No. Not Used	
38	1909486	Clutch Drum and Hub	1

REF No.	PART No.	DESCRIPTION	QTY.
PARTS NOT ILLUSTRATED			
Decals:			
	1984529	Product Logo Decal (on front lip of tine cover)	1
	1983094	Caution Decal (on rear of tine cover)	1
	1983095	Warning Decal (on rear of tine cover)	1
	1983096	Engine/Tine Speed Decal (on right handlebar)	1
	1983097	Engine Ignition Switch Decal (on right handlebar)	1
Kits and Accessories:			
	12568	Border Edger Attachment	1
	12569	Aerator Attachment	1
	12570	Power Rake Attachment	1
	H216454	Transport Wheels Attachment	1
	1983648	Tine Spacers (use when outer tines are removed for cultivating)	2
	1983647	Cup, Oil Measuring	1
	1982393	Replacement Tines. Includes Ref. No's. 25, 26, 35 and 36	1
	1909803	Transmission Assembly	1
	1983727	Tie Strap, 6", Nylon	2
	1981053	Tine Spacer Kit. Includes two Part No. 1983648	1

* Denotes parts usually available from a local hardware store.

NOTE: Contact an authorized Troy-Bilt dealer or the factory for replacement engine information. Contact an authorized engine dealer (for your make of engine) for engine service or parts. Refer to the engine nameplate for engine model and type information.

Replacement Parts – Figure 2

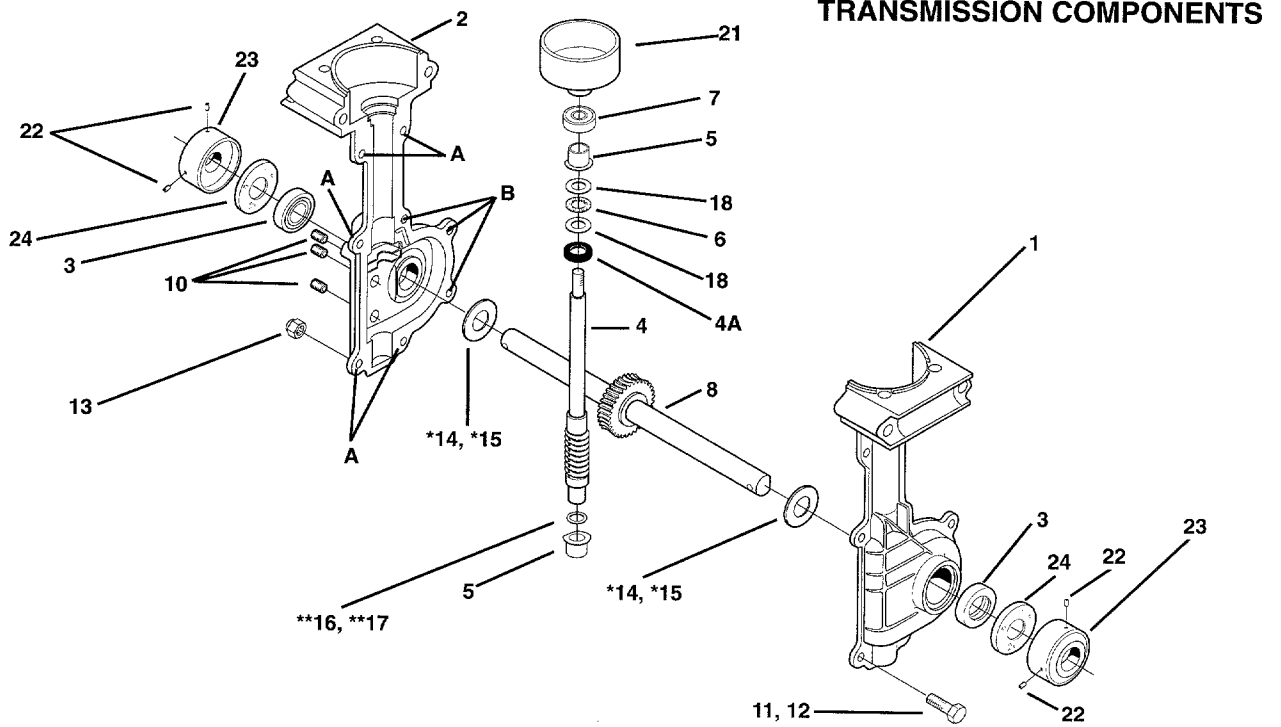

Replacement Parts – Figure 2

REF No.	PART No.	DESCRIPTION	QTY.	REF No.	PART No.	DESCRIPTION	QTY.
1	1915039	Transmission Case, with pressed-in bushing, left-side	1	12	1100069	Screw, 1/4-20 x 1 (three locations identified as "B" on transmission case)	3
2	1915040	Transmission Case, with pressed-in bushing, right-side	1	13	1817146	Locknut, Nyloc, 1/4-20.....	6
3	1983632	Oil Seal.....	2	14*	1983635	Thrust Washer, output (.050).....	A/R
4	1983634	Shaft, worm-input.....	1	15*	1983640	Thrust Washer, output (.040).....	A/R
4A	1909923	Oil Seal, input.....	1	16**	1983641	Thrust Washer, input (.020).....	A/R
5	1983731	Bearing, input.....	2	17**	1983642	Thrust Washer, input (.035).....	A/R
6	1983636	Bearing, thrust	1	18	1983638	Thrust Washer	2
7	1983637	Ball Bearing.....	1	19	----	This Ref. No. Not Used	
8	1904416	Shaft Assembly. Includes pressed-on worm gear and two ring lock pins.....	1	20	----	This Ref. No. Not Used	
9	----	This Ref. No. Not Used		21	1909486	Clutch Drum and Hub	1
10	1185741	Plug, 1/8	3	22	1747166	Set Screw, 1/4-28 x 3/8.....	4
11	1111600	Screw, 1/4-20 x 7/8 (five locations identified as "A" on transmission case	5	23	1915055	Dust Cover	2
				24	1983713	Felt Washer	2

* Used as required to reduce clearance and center the worm gear in the transmission case.

** Used as required to reduce clearance.

MAINTENANCE CHECKLIST

	Before Each Use	Regularly	Every 25 Hours of Use	Every 75 Hours of Use	Every 100 Hours of Use	End of Season
Are ignition switch wires securely attached?	X					
Make sure air cleaner assembly is secure.	X					
Check all nuts and bolts for tightness.		X				
Clean cooling system by removing debris from cylinder fins and carburetor area.		X				
Check transmission lubricant.*			X			X
Remove and service the air filters.** (service more frequently in dusty conditions)			X			
Have engine exhaust ports cleaned by an Authorized Tecumseh Engine Dealer.				X		
Clean dirt and debris from the equipment.						X
Clean and lubricate the tine shafts.		X				X
Check spark plug.***				X		

* After the first five (5) hours of use. Unless there is an obvious leak, the transmission should not require that any lubricant be added.

** Every 25 operating hours or every 3 months (service daily in extremely dusty conditions).

*** Annually or every 75 operating hours.

Note: For carburetor and engine speed adjustments, see your Authorized Tecumseh Service Dealer.

SPECIFICATIONS

Maximum Height— 51"

Height with Handlebars off— 17-1/4"

Width (at Handlebar Grips)— 16-1/4"

Tilling Width— 9" (approx.)

Tilling Width (outer tines off)— 6" (approx.)

Tine Construction— stamped steel, heat-treated, non-interchangeable

Controls: Engine Throttle Speed Lever

Engine Ignition Switch

Fuel Primer Button or Choke Lever

Depth Stake

Starting System— Manual rope pull (automatic rope rewind)

Fuel Tank Capacity— 20 ounces

Engine Make: Tecumseh TC-200

Engine Type: two-cycle (2-stroke), air-cooled.

Engine Displacement: 32.8cc (2 cu in). 1.6HP

Maximum Engine RPM: 5200

Fuel Mix Requirements: Use a ratio of 24 parts of unleaded regular gasoline to 1 part of quality two-cycle engine oil. See Page 12 in the Manual for specific instructions.

Engine Lubrication: Quality two-cycle engine oil must be mixed in the correct ratio (see above) with unleaded regular gasoline.

Spark Plug: Refer to separate Engine Owner's Manual. Gap plug to .030".

LIMITED WARRANTY

Date Warranty Begins	The warranty begins on the date of purchase.
What is Covered	<p>This product (except for the engine, as explained below) is warranted by Garden Way Incorporated to the original purchaser only, to be free of defects in material and workmanship under normal use and service for the following time periods:</p> <p>NON-COMMERCIAL RESIDENTIAL USE. 3 Years COMMERCIAL OR OTHER NON-RESIDENTIAL USE. 90 Days</p> <p>ENGINES: Engines used for non-commercial residential purposes are covered by the engine manufacturer's separate Limited Warranty. Garden Way Incorporated does, however, extend the length of the engine manufacturer's limited warranty, providing you with coverage for a total of 3 years. Please refer to the separate engine owner's manual for details concerning the engine manufacturer's Limited Warranty. <i>Engines used for commercial or other non-residential purposes are warranted by their respective manufacturer for the time periods indicated in the Limited Warranty printed in the separate engine manufacturer's owner's manual.</i></p>
What is Not Covered	<ol style="list-style-type: none">1. This warranty does not cover the periodic, normal replacement of parts that wear out such as seals, tines, tire tread, etc.2. This warranty does not cover damage, malfunctions or failures due to:<ol style="list-style-type: none">a) Use of unauthorized accessories or attachments.b) Misuse, accidents, or a lack of reasonable and necessary maintenance as specified in your product's Owner/Operator Manual (you may wish to keep records of maintenance and service).
What We Will Do For You	We will, at our option, repair or replace any part found to be defective in material or workmanship, without charge for parts and labor. However, charges for pick-up, delivery, and service calls are not covered by this warranty.
How to Obtain Non-Engine Related Warranty Service	<ul style="list-style-type: none">• You may be required to provide proof of the date of purchase (your sales receipt, for example).• Contact any TROY-BILT® Authorized Service Dealer (if purchased from a dealer, we recommend that you contact the same dealer you purchased this product from in order to give the dealer the opportunity to service you to your satisfaction). Refer to your local telephone directory for the name of your nearest dealer or call the TROY-BILT® Technical Service Department (see Toll-Free number below) for assistance. -OR-• Contact the TROY-BILT® Technical Service Department in Troy, N.Y. at this Toll-Free number: 1-800-520-5520.
How to Obtain Engine Warranty Service	Contact any service dealer that is authorized by the manufacturer of your engine. Please refer to the engine manufacturer's Limited Warranty for exact details on how to obtain warranty service. If you have any questions or concerns regarding engine warranty service, please call the TROY-BILT® Technical Service Department for assistance.
Disclaimer of Consequential Damages	<p>Garden Way Incorporated shall not be liable under any circumstances for any incidental or consequential damages or expense of any kind, including but not limited to cost of equipment rental, loss of profits, or cost of hiring services to perform tasks normally performed by the equipment.</p> <p>Any implied warranties, including without limitation any implied warranty of merchantability or fitness for a particular purpose, shall be limited in duration to a period of three years (90 days if product is purchased for commercial or other non-residential use) from the date of sale.</p>
Limitation of Implied Warranties	<p>SOME STATES DO NOT ALLOW THE EXCLUSION OR LIMITATION OF INCIDENTAL OR CONSEQUENTIAL DAMAGES, OR LIMITATIONS ON HOW LONG AN IMPLIED WARRANTY LASTS. THEREFORE, THE ABOVE LIMITATIONS OR EXCLUSIONS MAY NOT APPLY TO YOU.</p> <p>This warranty gives you specific legal rights, and you may also have other rights which vary from state to state.</p> <p>Garden Way Incorporated, 1 Garden Way, Troy, New York 12180</p>

For customer assistance, contact your nearest authorized dealer or:

GARDEN WAY INCORPORATED • 1 Garden Way • Troy, New York 12180

Customer Service: 1-800-437-8686 • Technical Service: 1-800-520-5520 • Parts Service: 1-800-648-6776 • FAX: (518) 391-7332

Outside the United States and Canada:

Customer Service: (518) 391-7007 • Technical Service: (518) 391-7008 • Parts Service: (518) 391-7006 • FAX (518) 391-7332